

Arduino Based Simulation and Mathematical Modelling for Lower Limb Exoskeleton

Rajnish Kumar Sharma¹, Dr. Devendra Vashist², John Devakumar³

¹Research Scholar,

²Professor and Head (Automobile and Aeronautical Engineering), University Proctor, MRIIRS, Faridabad, Haryana,

³Associate Professor, Department of Electronics and Communications, Delhi Skill and Entrepreneur University, New Delhi

Corresponding Author: Rajnish Kumar Sharma, Email: rajnishiph@gmail.com

DOI: <https://doi.org/10.52403/ijhsr.20240435>

ABSTRACT

Normal Human Locomotion is amongst the biggest challenge for ensuring the rehabilitation of Persons with Locomotor Disabilities (PwLDs). Suitably designed, developed automated featured orthotic intervention is the present need of rehabilitation. There are numerous types of automation systems for lower limb exoskeleton (LLE). Control systems of LLE technology has undergone significant advancements in the last decade, incorporating various interdisciplinary areas and improving several aspects of design and functionality. In the present study, the schematic and mathematical modelling for the LLE has been done. In order to capture the schematic of the Arduino based controller and associated circuitry the Proteus simulation software is used. All the stages of the gait cycles i.e. heel-strike, foot-flat, mid-stance, heel-off, toe off, acceleration, mid-swing and deceleration have been successfully performed by using Arduino based software.

Keywords: Orthotics, Lower Limb Exoskeleton, Controllers, Rehabilitation devices, Arduino, Locomotor disabilities

1. INTRODUCTION

Lower Limb Exoskeleton is a mechatronic device for improvement of the physical performance of the person with locomotor disabilities. It's technological mix of bionics, robotics, information science, and control [1]. LLE should include safety features, light in weight, affordable, energy efficient with optimum battery power[2]. LLE is used and applied for assistive, locomotor, neurological and geriatric conditions [3]. The core components of LLE are sensors, actuators and controllers [4]. LLE combines robotic strength and human intelligence and is fastened to the

wearer [5]. Human locomotion is an integration of complex sensory and motor commands involving muscle contraction and subsequent joint movements [6]. Arduino microcontrollers are able to read inputs i.e. light on a sensor, a finger on a button, and turn it into an output - activating a motor, turning on display [7]. Arduino includes features of editor, responsive interface, autocompletion, code navigation etc. [8]. Creating a comprehensive mathematical model of an Arduino-based lower extremity exoskeleton requires a deep understanding of mechanics, control theory, and system dynamics [9]. It's

essential to collaborate with experts in these fields and conduct thorough validation to ensure the model accurately represents the physical system's behaviour [10]. Mathematical modelling of an Arduino-based lower extremity exoskeleton involves describing the dynamics of the system, including the mechanical structure, actuators, sensors, and control algorithms [11]. The outline of the steps involved in creating such a model ; Kinematics Model; Dynamics Model; Actuator Model; Sensor Model; Control Algorithm; System Integration; Simulation and Analysis and Optimization and Validation[12]. The procedure for creating a schematic for an Arduino-based controller and its associated circuitry using Proteus simulation software includes- Start Proteus; Add Components;Wiring;Programming; Simulation and Troubleshooting[13].Creating an Arduino-based system to measure knee and hip angles in a lower limb exoskeleton involves several steps, including sensor selection, hardware setup, and coding[14]. General overview includes-Hardware Components ;IMU Sensors: Inertial Measurement Units (IMUs) are commonly used to measure orientation, one for each joint (knee and hip). IMUs typically contain gyroscopes, accelerometers, and magnetometers to measure orientation in 3D space [15]. The Arduino board should be compatible with the sensors and capable of handling the necessary calculations [16]. Connecting Cables are linked with sensor placement. An IMU is mounted on each joint of the exoskeleton which are securely attached and aligned with the axis of rotation of the joint [17].

2. Components

2.1 Arduino-board: Arduino board is able to read inputs i.e. light on a sensor, a finger on a button, and turn it into an output - activating a motor, turning on Display. Instructions may be

passed to the board for performing the desired movements.

2.2 Servo Motor - Servo motor is a rotary actuator that allows precise control of angular position. Servo system consists of a motor coupled with sensor for position feedback. It too requires a servo drive to complete the system. The drive uses the feedback sensor to precisely control the rotary position of the motor.

2.3 LED – It is a light emitting diode (LED) is a semiconductor device which emits light when some electrical current is allowed to flow through it. When current passes through an LED, the electrons re-combine with holes and emit light in the process.

2.4 LCD Display – It is a liquid-crystal display unit, also known as flat-panel display or other electronically modulated optical device that uses the light-modulating properties of liquid crystals combined with polarizers. Liquid crystals do not emit light directly, rather use a backlight or reflector for producing images in color or monochrome.

2.5. Tactile Switches - These small sized switches are placed on PCBs and are used to close an electrical circuit when button is pressed by a person. When button is pressed, the switches turn ON and when button is released, the switches turn OFF. A tactile switch is a switch whose operation is perceptible by touch.

3. METHODOLOGY

Electronic system of exoskeleton consists of four switches to provide input for operation to Arduino board. Once a set of instruction are passed to the microcontroller on the board and at the output of Arduino board. Four servo motors are used to provide the required mechanical power for the desired movements of the human gait cycle. On pressing switch SW1 yellow light get turn on which indicates that the system is ready. When button SW2 is pressed, the cyclic motion of locomotion gets initiated. This locomotion in terms of Gait

Cycle also appear on the LCD Display as demonstrated in the figures 4 to 12. When the system is to be stopped button SW3 is pressed, and it complete the current phase of the Gait Cycle before stopping. SW4 is provided to the patient in case at any point if he/she is not comfortable, on pressing SW4 LED start flickering to indicate the therapist/orthotist that there is an emergency.

We have used 4 servo motors for developing lower limb exoskeleton. Servo motors have been used for closed loop feedback control system to generate torque and velocity. Arduino microcontroller board is used to generate control pulses. Atmel 8-bit AVR microcontrollers are used in Arduino boards.

Inside a servo motor system there is small DC motor, a potentiometer (variable resistor) and a control circuit. The motor is attached by the gears to the control wheel. As the motor rotates, the potentiometer resistance changes. This change in resistance is detected by a control circuit that generate pulses of varying width to regulate amount of movement and its direction. This is called pulse width modulation-based control. When the shaft of the motor is in the desired position, the power supply to the motor is stopped. The pulse width modulation signal sent to the motor determines position of the shaft and based on the duration of the pulse the rotor will turn to the desired position.

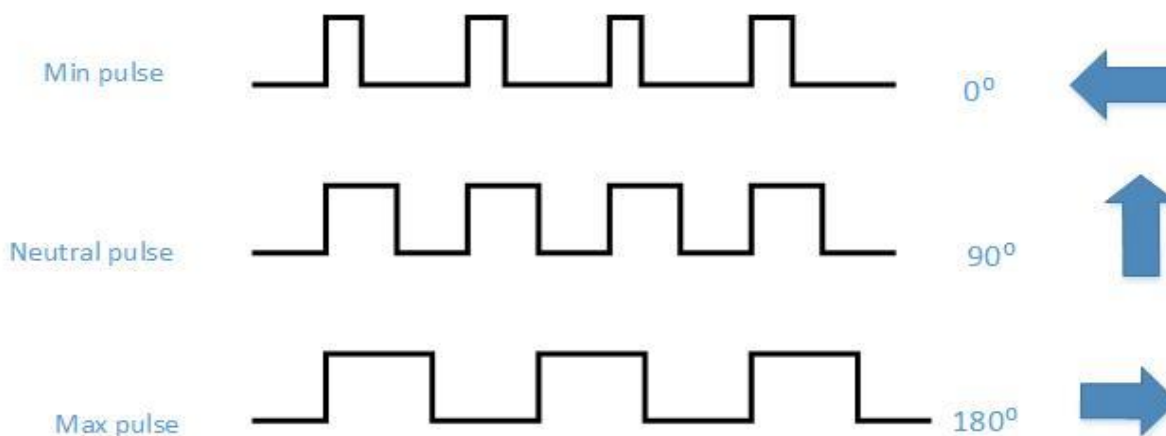

Figure 1: Servomotor armature movement for various pulse input

Motor's neutral position is the position, from where the servo can rotate equally in both directions. Pulses shorter than neutral pulse will make the motor move in counter clockwise direction towards 0° position. Pulses

larger than neutral pulse will make the motor move in clockwise direction towards 180° position. The schematic diagram of a DC servomotor is shown below.

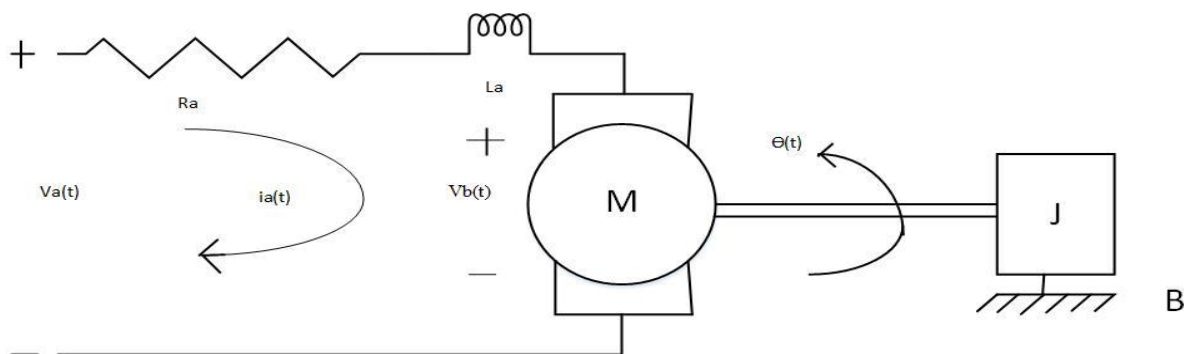

Figure 2: The mathematical equivalent diagram of servomotor

Where,

$v_a(t)$ = Armature input voltage

R_a = Resistance of Armature winding

L_a = Inductance of Armature winding

$v_b(t)$ = Back emf generated internally by angular rotation

J = Inertia of motor and load together

B = Damping in the motor and load relative to fixed Chassis

$i_a(t)$ = Armature current

Variables defined

Taking loop equation at the input electrical side of above figure 2, we get

$$v_a(t) = R_a i_a(t) + L_a \frac{di_a(t)}{dt} + v_b(t) \dots \quad (A)$$

$$v_b(t) = k_b \frac{d\theta(t)}{dt}; \text{ where } k_b \text{ is motors emf (electro motive force) constant} \quad (B)$$

The equations for the mechanical side of the system are

$$J \frac{d^2\theta(t)}{dt^2} + B \frac{d\theta(t)}{dt} = T_a(t) \quad (C)$$

$$T_a(t) = k_T i_a(t) \quad (D)$$

Where $T_a(t)$ the applied torque and k_T is the torque constant

From (A), (B), (C) and (D) we get

$$v_a(t) = R_a i_a(t) + L_a \frac{di_a(t)}{dt} + k_b \frac{d\theta(t)}{dt} \dots \quad (E)$$

$$J \frac{d^2\theta(t)}{dt^2} + B \frac{d\theta(t)}{dt} = k_T i_a(t) \dots \dots \quad (F)$$

There are three derivatives in the above equation. They are

$$\frac{di_a(t)}{dt}, \frac{d\theta(t)}{dt} \text{ and } \frac{d^2\theta(t)}{dt^2}$$

Therefore, there must be 3 variables in the state space model of system. The state variables are set of variables used to describe the mathematical state of a dynamic system. The state of a system describes enough about the system to determine the future behavior in the absence of external forces affecting the system.

The state variables are defined as outputs of integrators with x_1 being i_a , x_2 being θ and x_3 being $\frac{d\theta}{dt}$.

$$\text{i.e. } \frac{di_a(t)}{dt} = \dot{x}_1, \frac{d\theta(t)}{dt} = \dot{x}_2 \text{ and } \frac{d^2\theta}{dt^2} = \dot{x}_3$$

The dot ($\dot{}$) above variable indicates the derivative.

We can write equation E and F as

$$\frac{di_a(t)}{dt} = -\left(\frac{R_a}{L_a}\right) i_a(t) - \left(\frac{k_b}{L_a}\right) \frac{d\theta(t)}{dt} + \left(\frac{1}{L_a}\right) v_a(t) \quad (G)$$

$$\frac{d^2\theta(t)}{dt^2} = -\left(\frac{B}{J}\right) \frac{d\theta(t)}{dt} + \left(\frac{k_T}{J}\right) i_a(t) \quad (H)$$

Now in terms of state variables we can write

$$\dot{x}_1(t) = -\left(\frac{R_a}{L_a}\right) x_1(t) - \left(\frac{k_b}{L_a}\right) x_3(t) + \left(\frac{1}{L_a}\right) v_a(t) \quad (I)$$

$$\dot{x}_2(t) = x_3(t) \quad (J)$$

$$\dot{x}_3(t) = -\left(\frac{B}{J}\right) x_3(t) + \left(\frac{k_T}{J}\right) x_1(t) \quad (K)$$

$$x_2(t) = \theta(t) \quad (L)$$

The above four equations can be written in matrix form in terms of input ($v_a(t)$) and output variable ($\theta(t)$) as

$$\begin{bmatrix} \dot{x}_1(t) \\ \dot{x}_2(t) \\ \dot{x}_3(t) \end{bmatrix} = \begin{bmatrix} -\frac{R_a}{L_a} & 0 & -\frac{k_b}{L_a} \\ 0 & 0 & 1 \\ \frac{k_T}{J} & 0 & -\frac{B}{J} \end{bmatrix} \begin{bmatrix} x_1(t) \\ x_2(t) \\ x_3(t) \end{bmatrix} + \begin{bmatrix} 1/L_a \\ 0 \\ 0 \end{bmatrix} v_a(t) \quad (M)$$

$$\theta(t) = [0 \quad 1 \quad 0] \begin{bmatrix} x_1(t) \\ x_2(t) \\ x_3(t) \end{bmatrix}$$

Typical motion pattern of limb during a gait cycle for the hip, knee and angle are given in figure 3

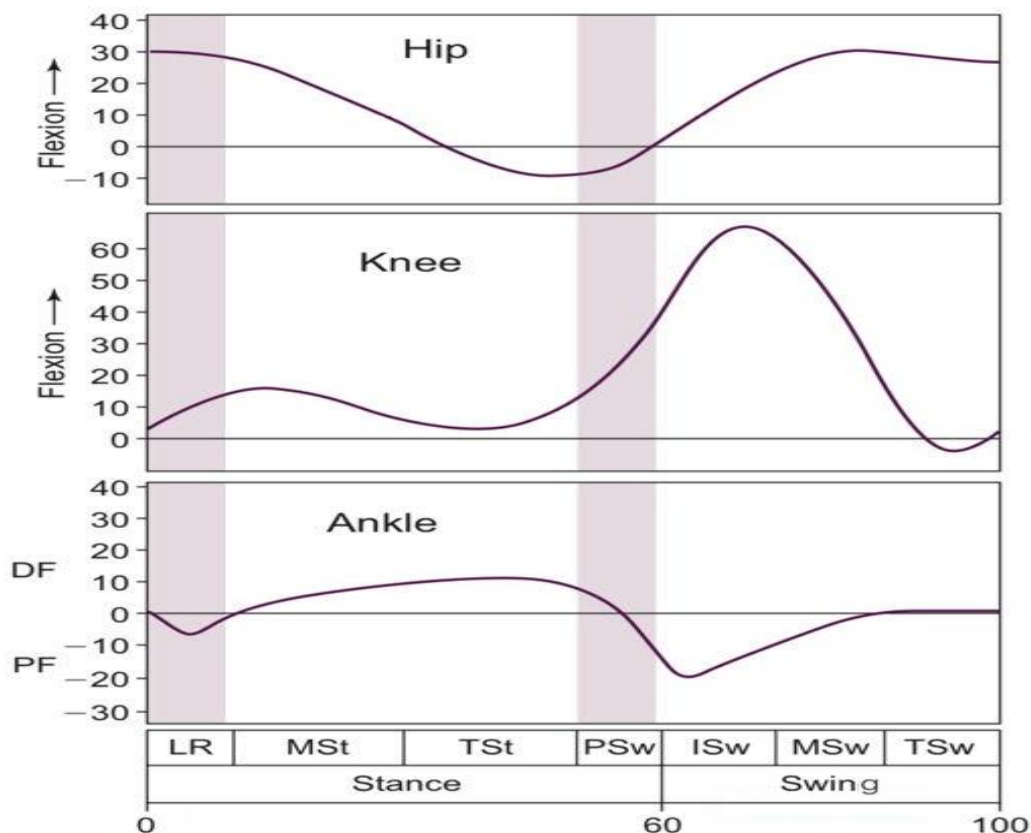

Figure 3 : Typical motion pattern of limb for one gait cycle for Hip, Knee and ankle

To make the servo motor whose state equation is given in equation (M), we need to generate armature voltage $v_a(t)$ using a controller. In the present case Arduino based controller board is used to generate pulses whose width are varied to generate different angular positions. The average value of rectangular pulses to be generated can be determined as

$$v_a(t) = A \frac{t_{on}}{T} \quad (N)$$

Where A = Amplitude of pulse

t_{on} = ON period of pulse

T = Total period of pulse

From the above expression we can find the ON period as

$$t_{on} = \frac{T \cdot v_a(t)}{A} \quad (O)$$

Controller (Arduino board) must generate pulses with ON period that follow above equation.

From figure 3 it has been found that at different instant of time the positions that is to be generated to complete one gait cycle. Using sinusoid-curve fitting interpolation function the expression for position has been generated in term of angular motion for hip and knee servo as

$$\text{Hip : } \theta(x) = 19.2779 \sin (1.08058x + 1.08977 + 8.95779) \quad (P)$$

$$\text{Knee : } \theta (x) = 17.2971 \sin (1.12357x + 11.7422 + 21.8457) \quad (Q)$$

We can determine the average ON time of pluses to be generated to make positional movement given in equation P and Q. Controller can generate pulses with ON time according to equation O to get average armature current for servo motors so that gait cycle can be completed.

4. Software used for Simulation

The Proteus Design Suite is a proprietary software tool used primarily for electronic design automation. It is a windows application for schematic capture, design and simulation.

It is available in different configurations, depending on the size of designs and the requirements for microcontroller simulation. The result of simulation is given in figure 4 to 8.

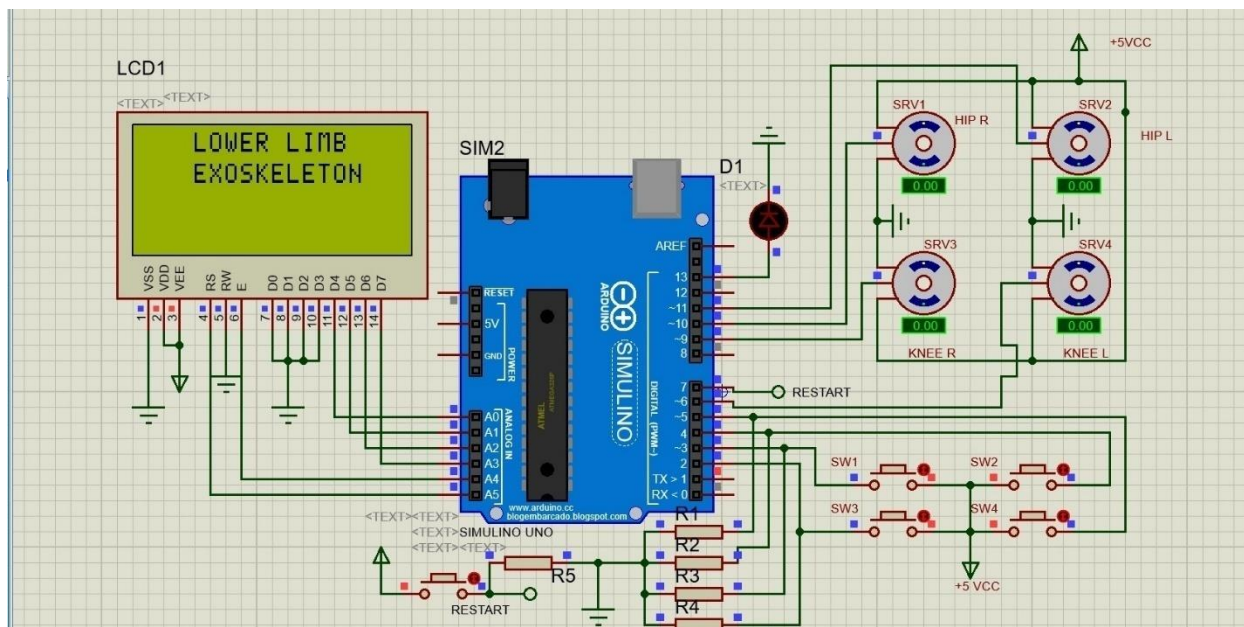

Figure 4: Integrated circuit of Arduino, servo motor and display panel

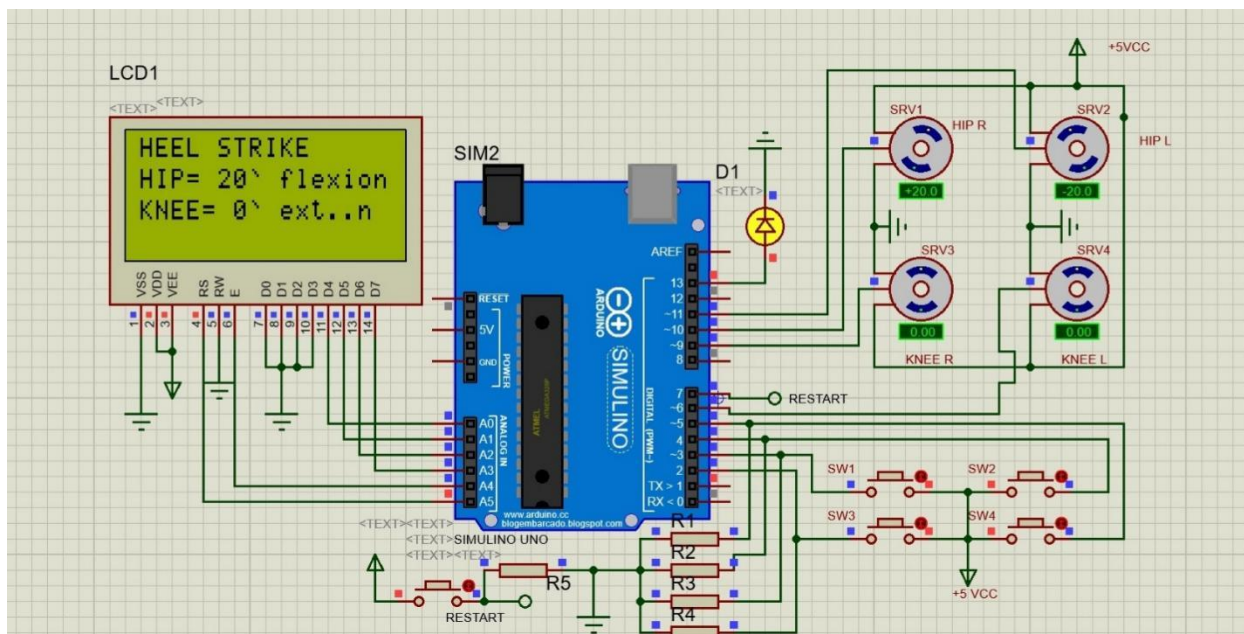

Figure 5 : Gait Phase – Heel Strike: The first phase of the gait cycle, when the foot begins to touch the ground

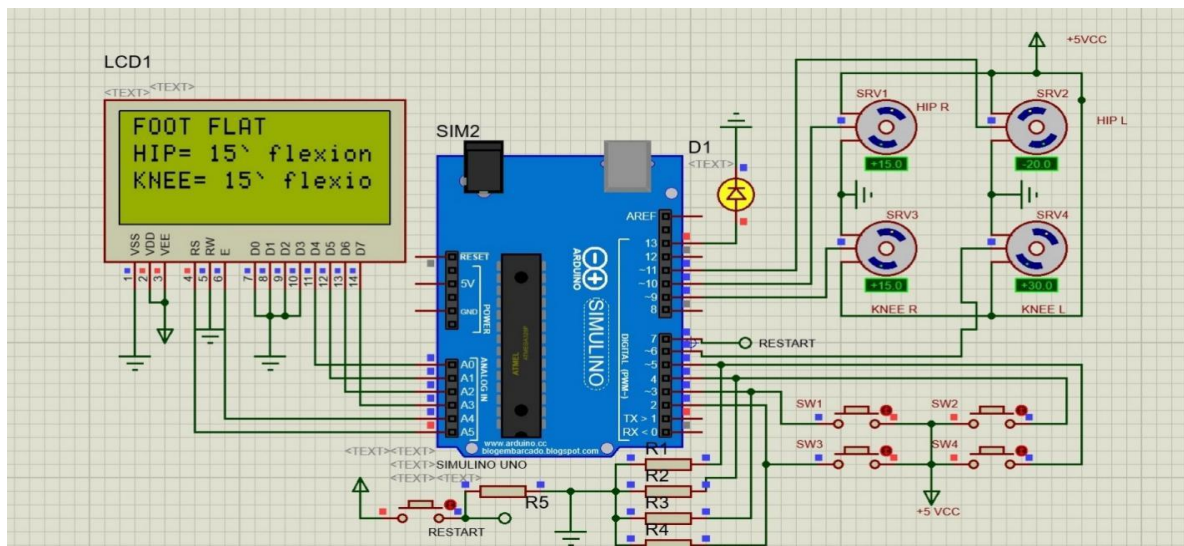

Figure 6: Gait Phase – Foot Flat: The body absorbs the impact of the foot by rolling in pronation

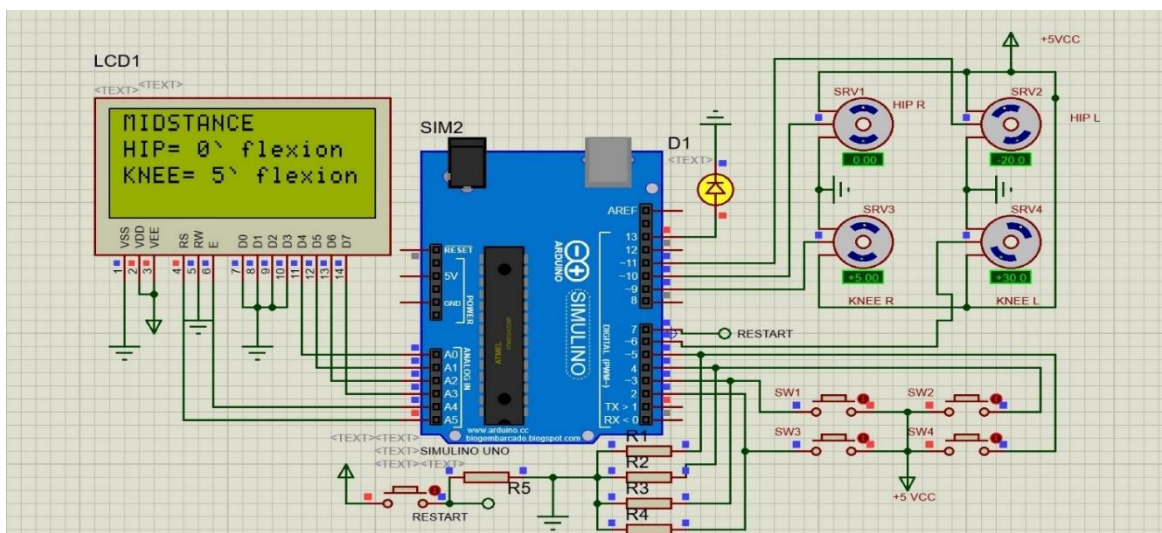

Figure 7: Gait Phase – Midstance: The shank rotates forward over the supporting foot, creating the second rocker motion of the cycle

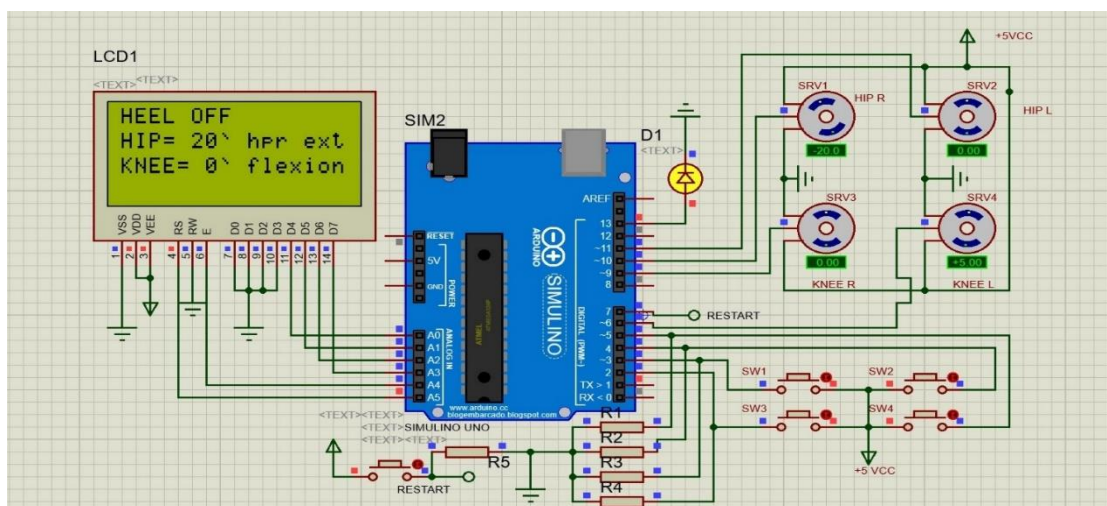

Figure 8: Gait Phase – Heel Off: : Body weight moves ahead of the forefoot

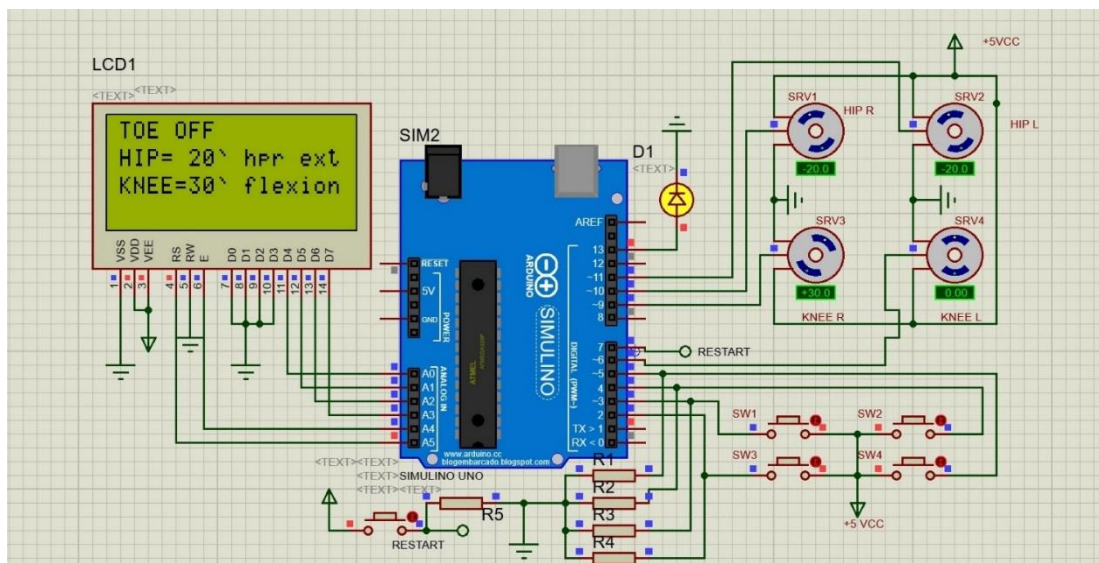

Figure 9: Gait Phase –Toe Off-The final stage of the stance phase of gait, and it involves pushing the toes into the ground while the ankle plantar-flexes, creating forward propulsion.

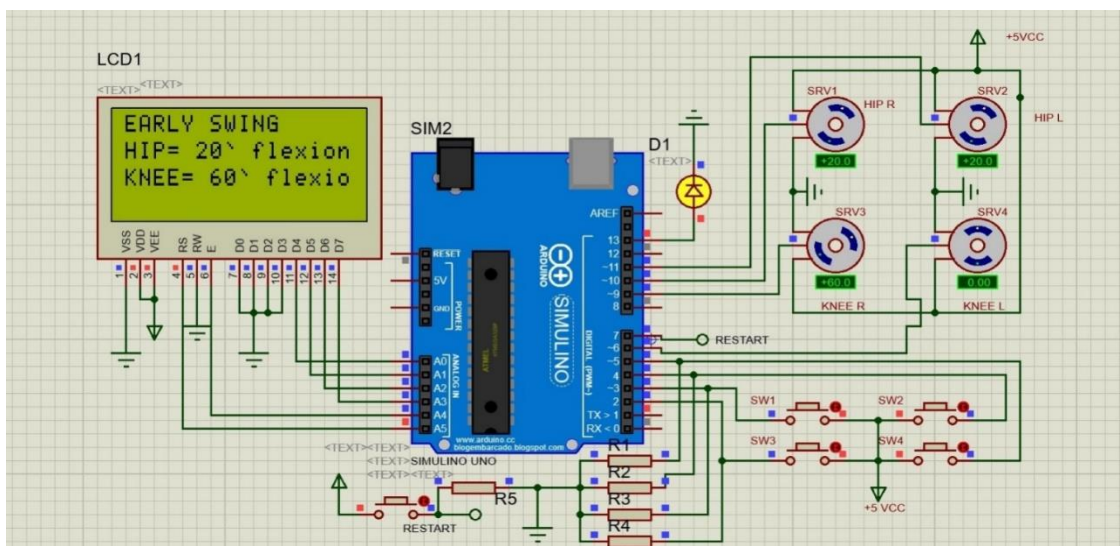

Figure 10: Gait Phase – Early Swing: The first sub-phase of gait, where the foot is lifted from the ground.

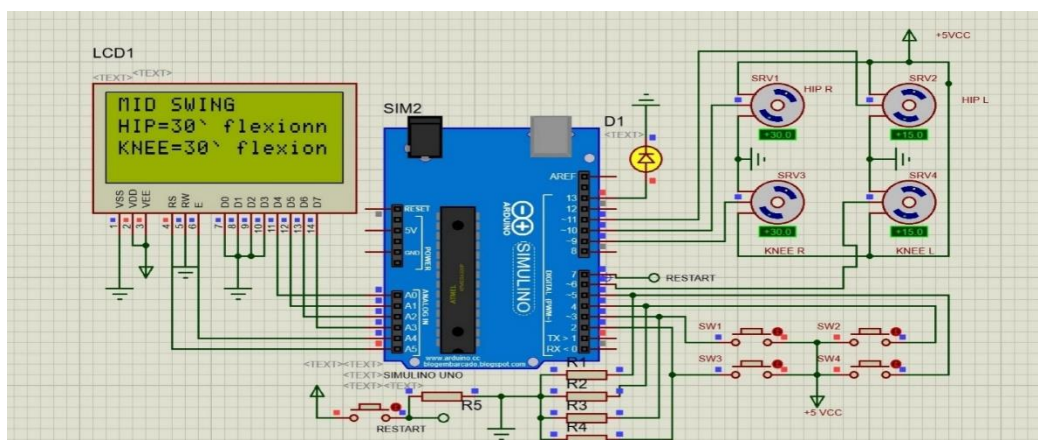

Figure 11: Gait Phase – Mid-Swing: the period from maximum knee flexion until the tibia is vertical or perpendicular to the ground.

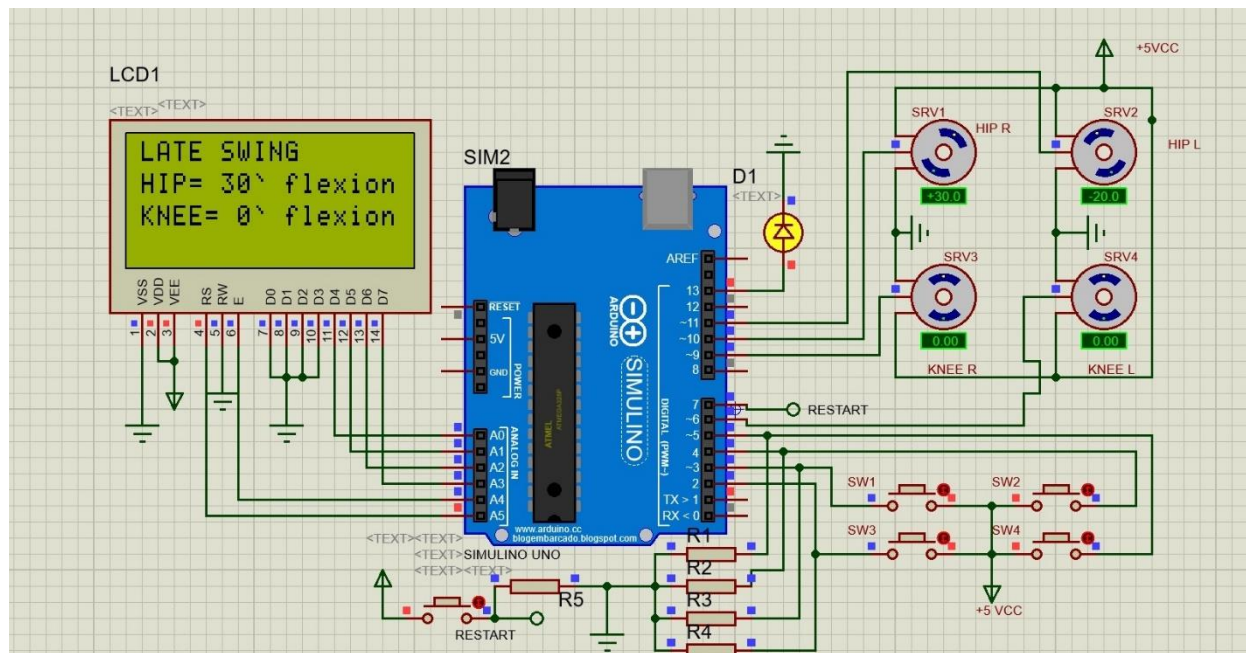

Figure 12; Gait Phase-Late Swing: The late swing phase of gait, also known as deceleration, begins when the swing leg is vertical and ends with initial contact.

4. RESULTS

There are large number of boards available in market that can be used for developing lower limb exoskeleton. Arduino Board are one such system. Arduino is able to perform in various stages of gait cycle. In the present study, the schematic and mathematical modelling for the LLE has been done. In order to capture the schematic of the Arduino based controller and associated circuitry the Proteus simulation software is used. All the stages of the gait cycles i.e. heel-strike, foot-flat, mid-stance, heel-off, toe off, acceleration, mid-swing and deceleration have been successfully performed by using Arduino based software. The automation of lower limb, at hip and knee level has been successfully done at software level. It has been found that at different instant of time the positions that is to be generated to complete one gait cycle. Using sinusoid-curve fitting interpolation function the expression for position has been generated in term of angular motion for hip and knee servo as;

$$\text{Hip: } \theta(x) = 19.2779 \sin(1.08058x + 1.08977 + 8.95779)$$

$$\text{Knee: } \theta(x) = 17.2971 \sin(1.12357x + 11.7422 + 21.8457)$$

We can determine the average ON time of pluses to be generated to make positional movement given in equation P and Q. Controller can generate pulses with ON time according to equation O to get average armature current for servo motors so that gait cycle can be completed. In future, the same can be extended to ankle joint so that a complete exoskeleton-based limb can be developed. Also, more fine tuning can be done by adding more sensors and generate position more smoothly. Further, speed factor may also be added to dynamically increase or decrease limb movement.

Declaration by Authors

Acknowledgement: None

Source of Funding: None

Conflict of Interest: The authors declare no conflict of interest.

5. REFERENCES

1. M. Dollar and H. Herr, "Lower extremity exoskeletons and active orthoses: challenges

- and state-of-the-art", *IEEE Transactions on robotics*, vol. 24, pp. 144-158, 2008.
2. Chen, H. Ma, L.-Y. Qin, F. Gao, K.-M. Chan, S.-W. Law, et al., "Recent developments and challenges of lower extremity exoskeletons", *Journal of Orthopaedic Translation*, vol. 5, pp. 26-37, 2016.
 3. M. Linares, 'Modelling and Control of Lower Limb Exoskeletons and Walking Aid for Fundamental Mobility Tasks', 2016.
 4. F. Casolo, S. Cinquemani and M. Cocetta, "On active lower limb exoskeletons actuators", 2008 5th International Symposium on Mechatronics and Its Applications, pp. 1-6, 2008.
 5. G. AL REZAGE, M. Tokhi and S. K. ALI, "Design and control of exoskeleton for elderly mobility", *ASSISTIVE ROBOTICS: Proceedings of the 18th International Conference on CLAWAR 2015*, pp. 67-74, 2016.
 6. *Gait Analysis : An Introduction* : Michle Whittle, Elsever Health Science Division, Rediff Books
 7. *Gait Analysis in the Science of Rehabilitation* Edited by Joel A DeLisa MD , Department of Veteran Affairs, Scientific and Technical Publications.
 8. H. F. Maqbool, M. A. B. Husman, M. I. Awad, A. Abouhossein, N. Iqbal, M. Tahir, et al., "Heuristic real-time detection of temporal gait events for lower limb amputees", *IEEE Sensors Journal*, vol. 19, pp. 3138-3148, 2018.
 9. J. C. Moreno, E. R. de Lima, A. F. Rufz, F. J. Brunetti and J. L. Pons, "Design and implementation of an inertial measurement unit for control of artificial limbs: application on leg orthoses", *Sensors and Actuators B: Chemical*, vol. 118, pp. 333-337, 2006.
 10. Karthik G.S. et.al,"IJIRST –International Journal for Innovative Research in Science & Technology| Volume 2 | Issue 11 | April 2016 ISSN (online): 2349-6010.
 11. L. I. Minchala, F. Astudillo-Salinas, K. Palacio-Baus, and A. Vazquez-Rodas, 'Mechatronic Design of a Lower Limb Exoskeleton', in *Design, Control and Applications of Mechatronic Systems in Engineering*, InTech, 2017. doi: 10.5772/67460.
 12. M. S. H. Bhuiyan, I. A. Choudhury, and M. Dahari, 'Development of a control system for artificially rehabilitated limbs: a review', *Biological Cybernetics*, vol. 109, no. 2. Springer Verlag, pp. 141–162, Apr. 01, 2015. doi: 10.1007/s00422-014-0635-1.
 13. P. S. M. Nacy, Nebras H. Ghaeb, and M. M. M. Abdullah, 'A review of Lower Limb Exoskeletons.pdf', *Innovative Systems Design and Engineering*, vol. 7, no. 1, pp. 1–12, 2016, [Online]. Available: www.iiste.org.
 14. R. Jiménez-Fabián and O. Verlinden, 'Review of control algorithms for robotic ankle systems in lower-limb orthoses, prostheses, and exoskeletons', *Medical Engineering and Physics*, vol. 34, no. 4. pp. 397–408, May 2012. doi: 10.1016/j.medengphy.2011.11.018.
 15. S.J. Suryawanshi and K. Janardhan Reddy "Conceptual Product Development of wheelchair for people disabled in legs" *International Journal of research in mechanical engineering* vol.1 , issue 2 pp.01-10, October December , 2013.
 16. T. J Alexander B.Martin, J.S.S.T Rao and A. Ali, " Development of a transformation electrically powered wheel chair into a medical emergency stretcher ", *international journal of Pharmacy and tech*.
 17. Ü. Önen, F. M. Botsalı, M. Kalyoncu, Y. Şahin, and M. Tinkır, 'Design and Motion Control of a Lower Limb Robotic Exoskeleton', in *Design, Control and Applications of Mechatronic Systems in Engineering*, InTech, 2017. doi: 10.5772/67458.

How to cite this article: Rajnish Kumar Sharma, Devendra Vashist, John Devakumar. *Arduino based simulation and mathematical modelling for lower limb exoskeleton. Int J Health Sci Res.* 2024; 14(4):243-252. DOI: [10.52403/ijhsr.20240435](https://doi.org/10.52403/ijhsr.20240435)
